

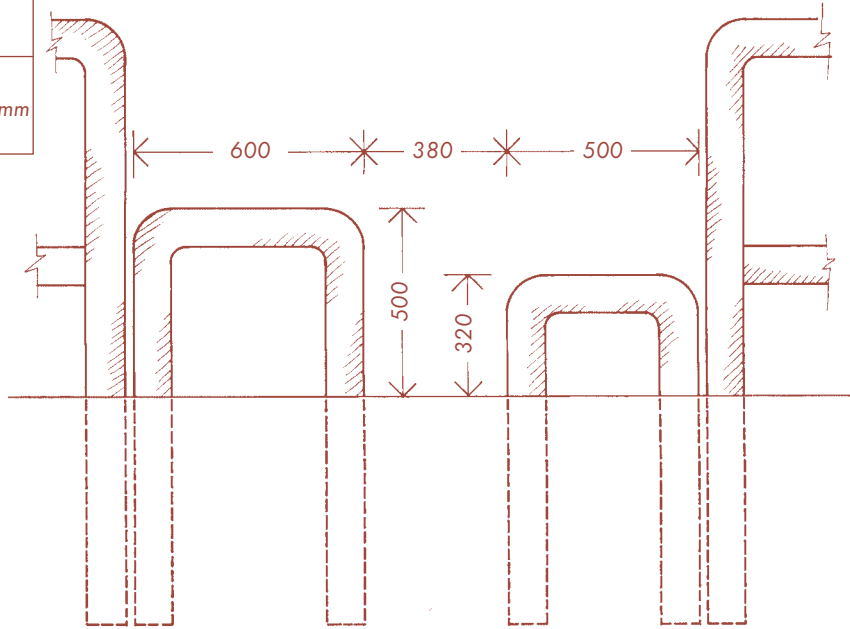

1.6A York Chicane : Front Elevation
Scale 1:20
0 1000mm

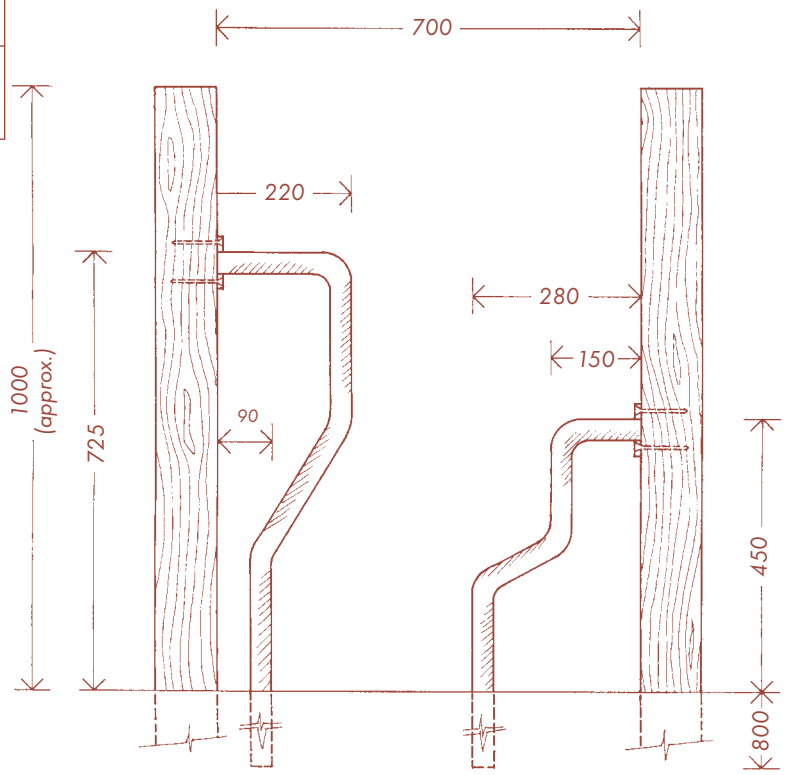

1.6B Fife Chicane : Front Elevation
Scale 1:12.5
0 100mm



	Conforms to BS 5709	Ease of use for Pedestrians	Accessible to Motorised Wheelchair Users	Accessible to Manual Wheelchair and Pushchair Users	Accessible to Horseriders	Accessible to Pedal Cyclists	Accessible to Motorcyclists	Accessible to Motor Cars
York	X	☺	X	X	✓ ¹	✓	X ²	X
Fife	X	☹	X	X	X	✓	X ²	X

¹ accessible, but not very suitable or convenient for the purpose

² but may be accessible to lighter trail bikes

