

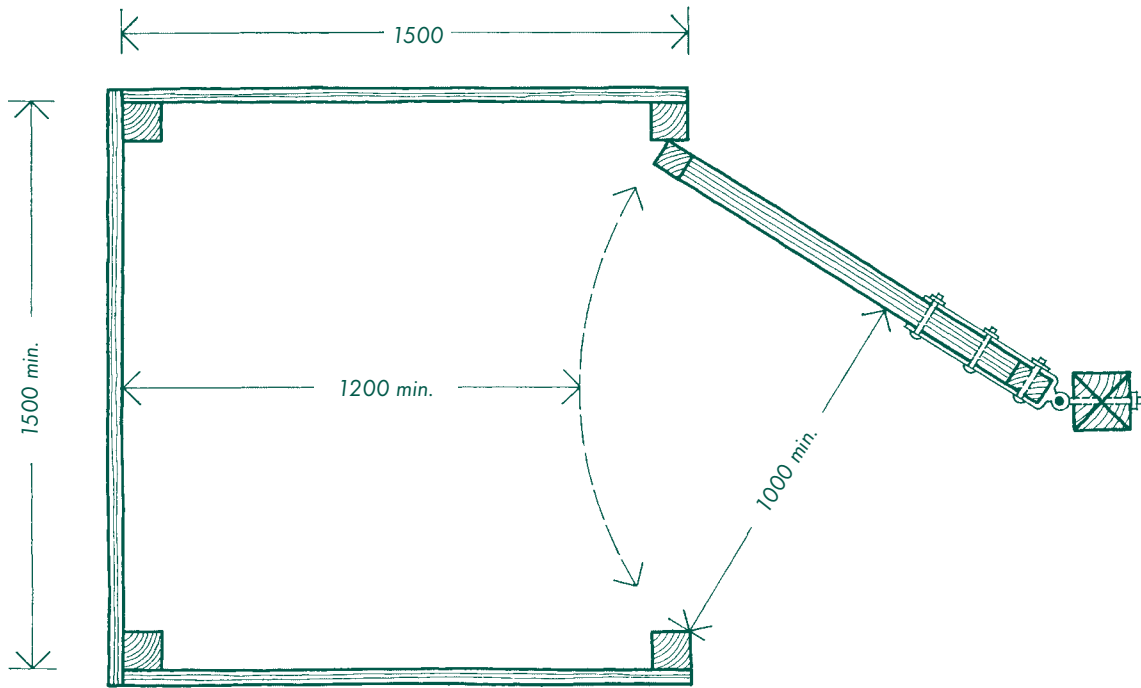

2.10A Plan
Scale 1:20
0 1000mm

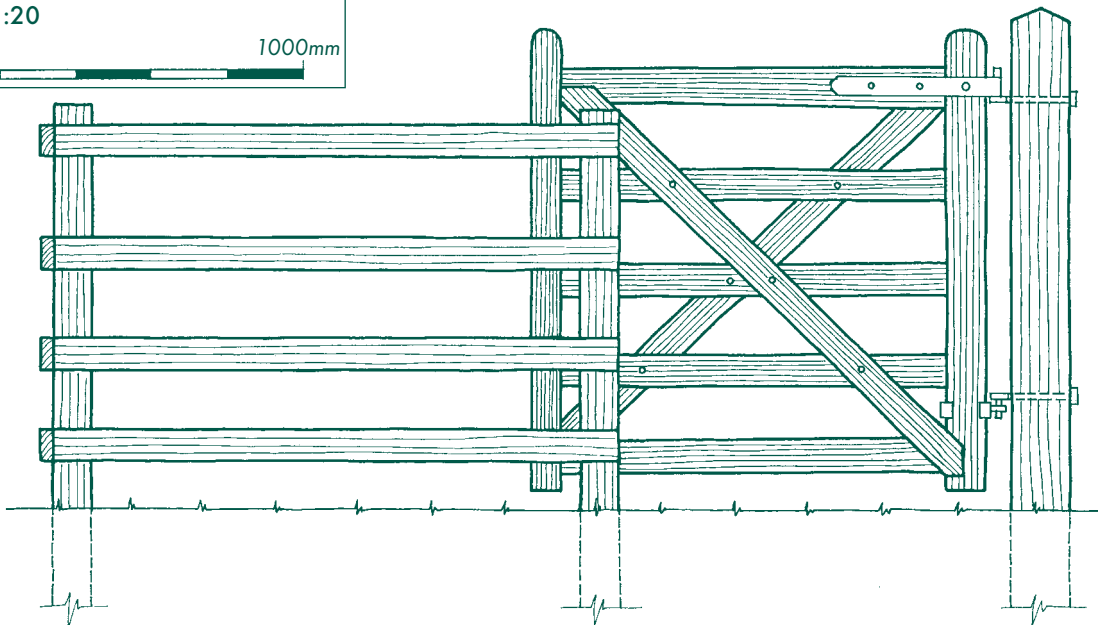

2.10B Side Elevation
Scale 1:20
0 1000mm



Conforms to BS 5709	Stockproof	Ease of use for Pedestrians	Accessible to Motorised Wheelchair Users	Accessible to Manual Wheelchair and Pushchair Users	Accessible to Horseriders	Accessible to Pedal Cyclists	Accessible to Motorcyclists
✓	✓ ¹	☺	✗	✓	✗	✓ ²	✗

¹ assumes the fitting of self-closing hinges and/or latches

² accessible but not very convenient or suitable for the purpose

