



Information Sheet **No.7.3**
Timber Bench

(Page 1 of 2)

7.3A Front Elevation

Scale 1:20

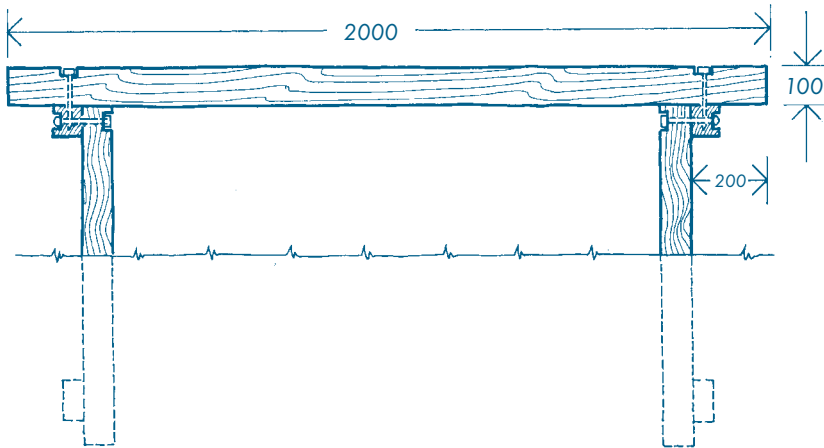

7.3B End Elevation

Scale 1:20

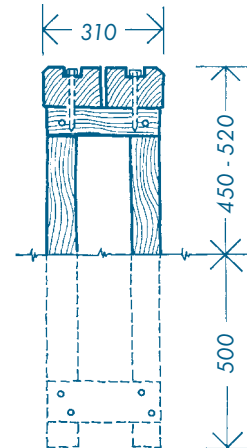

7.3C Detail of fixings

Scale 1:5

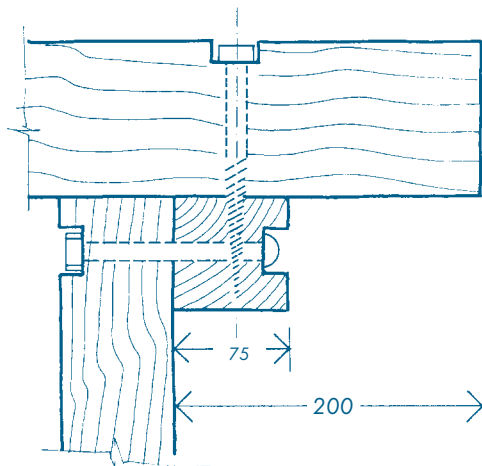

7.3D Perspective

Not to Scale

