



**7.4A Front Elevation**

Scale 1:20



**7.4B Side Elevation (Alternative fixing)**

Scale 1:20

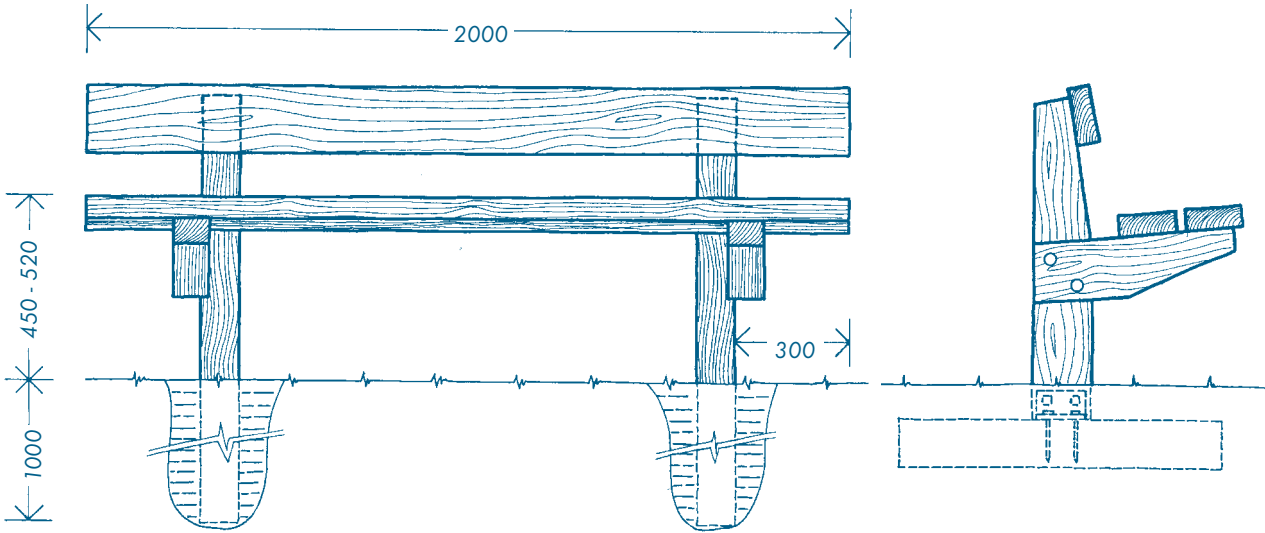

**7.4C Side Elevation**

Scale 1:10



**7.4D Rear Elevation - detail of seat support**

Scale 1:10

