

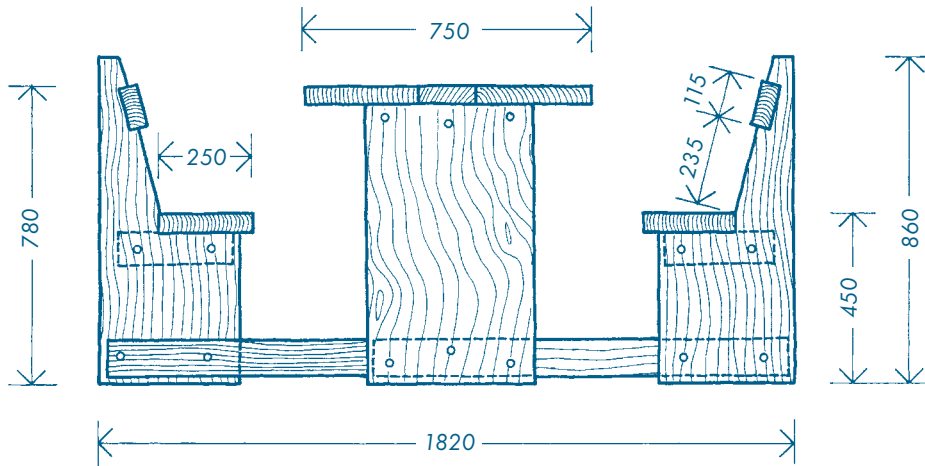

7.6A Side Elevation

Scale 1:20



7.6B Perspective

Not to Scale

